

Phononic C600 Merchandising Refrigerator

Technical Data Sheet

The Phononic C600 Merchandising Refrigerator is the only countertop commercial refrigerator that uses solid-state technology to create and maintain consistent cooling. From checkout counters and bar tops to concession stands and even merchandise displays, the Phononic C600 Merchandising Refrigerator holds up to 30% more in your smallest spaces. This modern, quiet, compact fridge allows you to place high-margin products exactly where customers will notice them.

A Phononic refrigerator allows you to say goodbye to noisy, bulky and energy-hogging compressors and fans and say hello to:

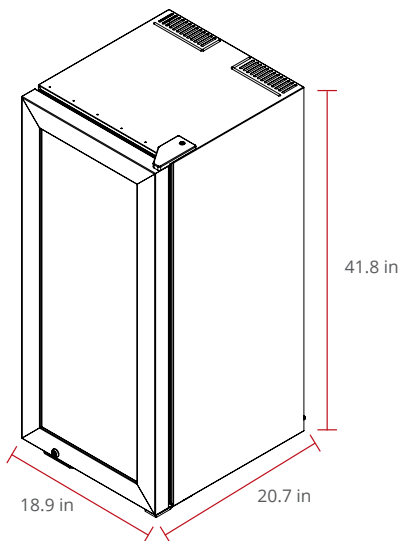

Features

- Customizable look and branding
- Solid-state refrigeration system
- Low temperature heat exhaust
- Self-closing door
- Non-hazardous refrigerant

Additional Accessories

- Extra shelves
- Data dongle

Up to 30% MORE storage:
Stock up to 125 twelve oz. cans or 80 twenty oz. bottles

Phononic's compressor-free approach is setting new standards in capacity, reliability, efficiency, and sustainability, so you can:



Sell more with prime placement and greater capacity

Entice customers with a greater number of products directly visible at eye level.



Deliver consistent cooling throughout cabinet

Best-in-class temperature stability and uniformity



Gain insights into your business

Track door openings to discover trends and capture customer use and operations data for preventative maintenance.



Cut maintenance time and costs

Replace compressor-based refrigerators with more reliable solid-state technology and spend less time maintaining them.

Phononic C600 Merchandising Refrigerator

Basic Information	Model	PFR052SGB-EB1	
	Materials	CRS, PVC, Aluminum, Tempered Glass	
	Power Input	120V, 60Hz	
	Power Cord	1.8 Meter/ 6 ft., NEMA 5-15	
	Internal Lighting	LED Lights on Door	
Performance	Setpoint Temperature	2°C, 4°C, 6°C	
	Temperature Uniformity	± 1.5°C	
	Temperature Stability	± 2°C	
	Noise Level	42 dBA (steady-state)	
	Energy Requirements	1.91 kWh/day @ 24°C Ambient/75°F	
Safety	Amps	7.1 Amps (Pulldown), 0.65A (Steady State)	
	Certifications	UL, NSF	
	Packing Factor	125 twelve oz. cans or 80 twenty oz. bottles	
	Refrigerant	R744 (CO2)	
	Internal Volume	5.2 cu Ft	
Storage	Shelves	3	
	Catch Tray	Yes	
	Internal Dimensions	14.7"W x 15.4"D x 38.7"H	37.3 cm W x 39.1 cm D x 98.3 cm H
	External Dimensions	18.9"W x 20.7"D x 41.8"H	48 cm W x 52.6 cm D x 106.2 cm H
	Weight	190 lbs	
Installation	Minimum Clearance Requirement	100mm (rear, top)	
	Heat Pump	10 years	
	Full Refrigerator Parts and Labor	1 year	
Warranty	Extended Warranty	Available up to 5 years	

Version 1002C