

# Undercounter Refrigerator 5.5

## Technical Data Sheet

The Phononic Undercounter Refrigerator 5.5 is the only undercounter commercial refrigerator that uses solid-state technology to create and maintain consistent cooling. Compact, modern and quiet, it holds up to 40% more in a small space, allowing you to fit more equipment into your tight kitchen or barback space. In the Undercounter Refrigerator 5.5, high-margin products become easily accessible to customers, instead of stocked in the back of the store.

A Phononic fridge allows you to say goodbye to noisy, bulky and energy-hogging compressors and fans and say hello to:

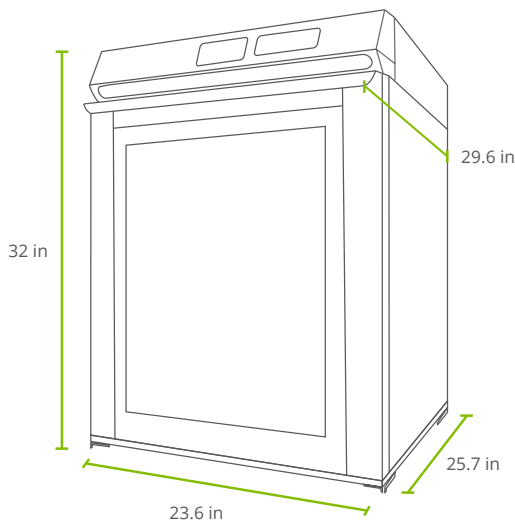

### Features

- Customizable look for cabinet installations
- Solid-state refrigeration system
- Elevated front venting, gentle heat exhaust
- Self-contained, heated condensation tray
- Optional embedded alarms and locking
- Self-closing door
- Non-hazardous refrigerant

### Additional Accessories

- Extra shelves
- Slide-out baskets
- Caster set
- Stacking kit
- Anti-tip bracket
- Seismic bracket
- Low-profile power cord

**Up to 40% MORE storage:**  
**Stock up to 220 twelve oz. cans or 54 twenty oz. bottles**

Phononic's compressor-free approach is setting new standards in capacity, reliability, efficiency, sustainability and security, so you can:



#### Sell more with greater capacity

Display more products wherever they'll reach the most hungry and thirsty customers.



#### Deliver consistent cooling at lower cost

Increase temperature stability by up to 163% and cut energy costs by up to 30%.



#### Gain insights into your business

Track door openings to discover trends and capture customer use and operations data for preventative maintenance.



#### Cut maintenance time and costs

Replace compressor-based refrigerators with more reliable solid-state technology and spend less time maintaining them.

## Phononic Undercounter Refrigerator 5.5

Basic Information	Model	Solid Door – PFR055SSB-002 Glass Door – PFR055SSG-002		
	Materials	Painted Steel, Stainless Steel, Aluminum, Tempered Glass		
	Display	Full Color 4.3" integrated TFT display with touch control		
	Power Input	120V, 60Hz		
	Wireless	2.4 GHz 802.11 b/g/n compatible		
	Power Cord	1.8 Meter, NEMA 5-15		
	Internal Lighting	Yes		
Performance	Programmable Temperature	2 °C – 8 °C		
	Temperature Uniformity	+/- 1 °C from center air		
	Temperature Stability	< 0.5 °C		
	Noise Level	< 35 dBA		
	Energy Requirements	< 1.2 - 2.4 kWh/24hrs @ 4 °C		
	Energy Per 12 oz Can	0.005 - 0.01 kWh per can/24 hrs		
	Max. Heat Reject	550 BTU/hr		
	Amps	5 Amps Max, 3 Amps Steady State		
	Certifications	C MET US, CE, RoHS, Reach, NRTL/CAN		
	Refrigeration Systems	Redundant + Solid State Semiconductor		
Safety	Lock	Electronic Lock		
	Controlled Access	Yes, 3 levels		
	Resettable Min/Max Temperature Readings	Yes		
	Dry Contacts for Remote System Monitoring	Yes		
	System Alerts	Yes		
	Refrigerant	R744 (CO2), R718 (H2O)		
Storage	Internal Volume	5.5 Cu. Ft.		
	Shelves	4 Epoxy Coated Steel Shelves with Optional Dividers		
	Slider Basket	1 Optional		
	Packing Factor	220 twelve oz. cans or 54 twenty oz. bottles		
	Internal	19.5"W x 20.5"D x 23"H	49.5 cm W x 52.1 cm D x 58.4 cm H	
Installation	External	23.6"W x 25.7"D x 32"H	60 cm W x 65.3 cm D x 81.3 cm H	
	Weight	Solid Door – 131 Pounds	Glass Door – 141 Pounds	
	Venting	Elevated Front Venting		
	ADA Compliant	Yes		
	Minimum Clearance Requirement	0" Top, Side and Back		
Warranty	Heat Pump	10 years		
	Full Refrigerator Parts and Labor	2 years		
	Extended Warranty	Available up to year 5		

Version 1003A