

Phononic F200 Merchandising Freezer

Technical Data Sheet

The Phononic F200 Merchandising Freezer is the world's only commercial merchandising freezer designed specifically to provide distributed refrigeration to improve customer satisfaction while driving higher sales. Compact and quiet, you can now move high-margin frozen products from sub-optimal placements and instead offer frozen products at checkout, front end or on the end cap where space, noise or vibration constraints may have prohibited mechanical freezer placement. The Phononic F200 Merchandising Freezer fits perfectly in grocery and convenience stores, restaurants, and entertainment venues to improve customer satisfaction by providing quick and easy access to frozen impulse products at checkout.

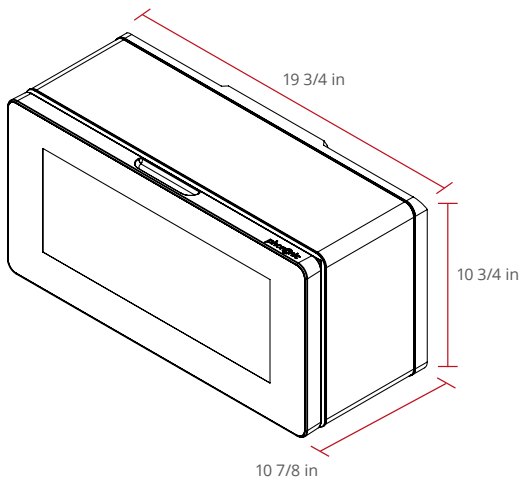

Features

- Solid-state freezer system delivering consistent performance at -18 °C
- Small form factor, low heat output and vibration for optimal retail placement at the point of sale
- Easy-to-access angled slide door with balanced close mechanism
- Non-hazardous refrigerant
- Clear bin for inventory view
- Customizable advertisement utilizing field-interchangeable graphics

Unlock new merchandising opportunities

Phononic's compressor-free cooling is setting new standards in capacity, reliability, efficiency and sustainability, so you can:



Sell more at the point of sale

Display the most profitable frozen products where they'll reach the most customers - not at perimeter walls, as is common today.



Deliver consistent cooling at lower cost

Fast recovery and optimal design efficiently keep food frozen, even with frequent openings.



Cut maintenance time and costs

Long-lasting, reliable solid-state cooling eliminates the mechanical parts that are most prone to breakdown.



Customize display messages

Utilize in-store advertisements to drive behavior and increase impulse sales.

Version 1001E

Phononic F200 Merchandising Freezer

Basic Information	Model	PFF004SGA-PB1
	Materials	Painted Steel, Aluminum, Plastic, Tempered Glass
	Power Input	100-240VAC 50Hz-60Hz (external adapter, 200x100x30mm)
	Power Cord	1.8 Meter, NEMA 5-15
	Internal Lighting	Yes
Performance	Temperature Set-point	-18 °C, -0.4 °F
	Temperature Uniformity	3 °C
	Temperature Stability	< 1 °C
	Noise Level	39 dBA
	Energy	3.7 kWh/day @ 24 °C Ambient / 75.2 °F
	Rated Amps	3.5 Amps
Safety	Certifications	UL 471, FCC, NSF-7
Storage	Refrigerant	R744 (CO ₂)
	Internal Volume	0.4 cubic feet
	Storage Bin	Clear Polycarbonate
	Bin Dimensions	390mm x 163mm x 142mm
	Packing Factor	24 - 48 Novelties
Installation	Internal Dimensions	16.9" W x 6.2" D x 7.0" H; 429mm W x 157mm D x 179mm H
	External Dimensions	19 3/4" W x 10 7/8" D x 10 3/4" H; 501mm W x 276mm D x 273mm H
	Shipping Weight	42 lbs
	Product Weight	35 lbs
Warranty	Minimum Clearance Requirement	50mm top, 150mm back
	Heat Pump	10 years
	Full Freezer Parts and Labor	1 year

Version 1001E