

Merchandising Refrigerator 5.2

Technical Data Sheet

The Phononic Merchandising Refrigerator 5.2 is the only countertop commercial refrigerator that uses solid-state technology to create and maintain consistent cooling. From checkout counters and bar tops to concession stands and even merchandise displays, the Merchandising Refrigerator 5.2 holds up to 30% more in your smallest spaces. This modern, quiet, compact fridge allows you to place high-margin products exactly where customers will notice them.

A Phononic fridge allows you to say goodbye to noisy, bulky and energy-hogging compressors and fans and say hello to:

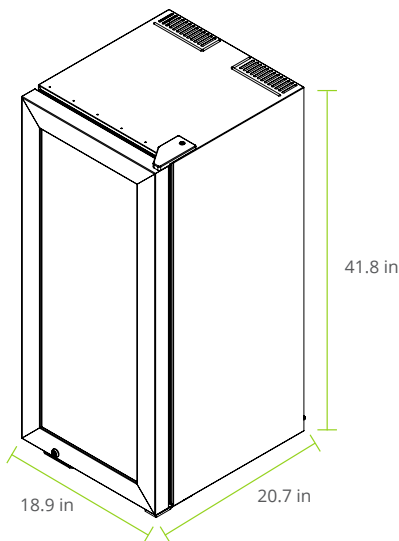

Features

- Customizable look and branding
- Solid-state refrigeration system
- Gentle heat exhaust
- Mechanical lock
- Self-closing door
- Non-hazardous refrigerant

Additional Accessories

- Extra shelves
- Anti-tip bracket
- Low-profile power cord

Up to 30% MORE storage:
Stock up to 125 twelve oz. cans or 80 twenty oz. bottles

Phononic's compressor-free approach is setting new standards in capacity, reliability, efficiency, sustainability and security, so you can:



Sell more with prime placement and greater capacity

Entice customers with a greater number of products directly visible at eye level.



Deliver consistent cooling at lower cost

Increase temperature stability by up to 163% and cut energy costs by up to 30%.



Gain insights into your business

Track door openings to discover trends and capture customer use and operations data for preventative maintenance.



Cut maintenance time and costs

Replace compressor-based refrigerators with more reliable solid-state technology and spend less time maintaining them.

Merchandising Refrigerator 5.2

Basic Information	Model	PFR052SGA-001	
	Materials	CRS, PVC, Aluminum, Tempered Glass	
	Display	n/a	
	Power Input	120V, 60Hz	
	Wireless	n/a	
	Power Cord	1.8 Meter, NEMA 5-15	
	Internal Lighting	Yes	
Performance	Programmable Temperature	2°C, 4°C, 6°C	
	Temperature Uniformity	± 3°C from center air	
	Temperature Stability	± 2°C	
	Noise Level	42 dBA (steady-state) < 65 dBA (max)	
	Energy Requirements	<1.37 kWh/day	
	ENERGY STAR® Certified	No	
	Max. Heat Reject	690 BTU/hr	
	Amps	7.1A Max, 0.65A Steady State	
	Certifications	UL, NSF	
	Redundant Refrigeration Systems	Yes	
Safety	Lock	Yes (Mechanical Keyed)	
	Controlled Access	n/a	
	Resettable Min/Max Temperature Readings	n/a	
	Dry Contacts for Remote System Monitoring	n/a	
	System Alerts	n/a	
	Refrigerant	R744 (CO ₂), R718 (H ₂ O)	
Storage	Internal Volume	5.2 cu Ft	
	Shelves	4	
	Catch Tray	1	
	Packing Factor	125 twelve oz. cans or 80 twenty oz. bottles	
	Installation	Internal Dimensions	14.7"W x 15.4"D x 38.7"H
External Dimensions		18.9"W x 20.7"D x 41.8"H	48 cm W x 52.6 cm D x 106.2 cm H
Weight		190 lbs	
ADA Compliant		No	
Warranty	Minimum Clearance Requirement	100mm (rear, top)	
	Heat Pump	10 years	
	Full Refrigerator Parts and Labor	2 years	
	Extended Warranty	Available up to 5 years	

Version 1002B