

Merchandising Refrigerator 5.2

Technical Data Sheet

The Phononic Merchandising Refrigerator 5.2 is the only countertop commercial refrigerator that uses solid-state technology to create and maintain consistent cooling. From checkout counters and bar tops to concession stands and even merchandise displays, the Merchandising Refrigerator 5.2 holds up to 40% more in your smallest spaces. This modern, quiet, compact fridge allows you to place high-margin products exactly where customers will notice them.

A Phononic fridge allows you to say goodbye to noisy, bulky and energy-hogging compressors and fans and say hello to:

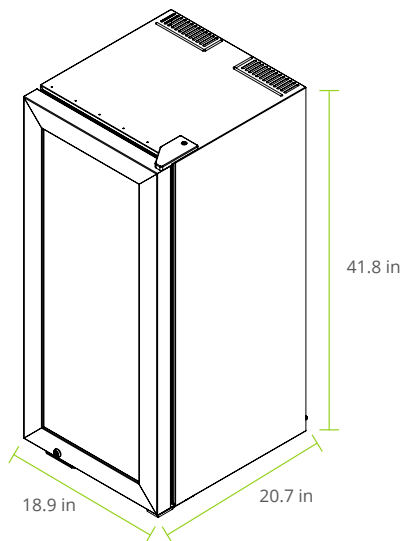

Features

- Customizable look and branding
- Solid-state refrigeration system
- Gentle heat exhaust
- Mechanical lock
- Self-closing door
- Non-hazardous refrigerant

Additional Accessories

- Extra shelves
- Anti-tip bracket
- Low-profile power cord

Up to 40% MORE storage:
Stock up to 125 twelve oz. cans or 80 twenty oz. bottles

Phononic's compressor-free approach is setting new standards in capacity, reliability, efficiency, sustainability and security, so you can:



Sell more with prime placement and greater capacity

Entice customers with a greater number of products directly visible at eye level.



Deliver consistent cooling at lower cost

Increase temperature stability by up to 163% and cut energy costs by up to 30%.



Gain insights into your business

Track door openings to discover trends and capture customer use and operations data for preventative maintenance.



Cut maintenance time and costs

Replace compressor-based refrigerators with more reliable solid-state technology and spend less time maintaining them.

Merchandising Refrigerator 5.2

Basic Information	Model	PFR052SGA-001		
	Materials	CRS, PVC, Aluminum, Tempered Glass		
	Display	n/a		
	Power Input	120V, 60Hz		
	Wireless	n/a		
	Power Cord	1.8 Meter, NEMA 5-15		
	Internal Lighting	Yes		
Performance	Programmable Temperature	2°C, 4°C, 6°C		
	Temperature Uniformity	± 3°C from center air		
	Temperature Stability	± 2°C		
	Noise Level	42 dBA (steady-state) < 65 dBA (max)		
	Energy Requirements	<1.37 kWh/day		
	ENERGY STAR® Certified	No		
	Max. Heat Reject	690 BTU/hr		
	Amps	7.1A Max, 0.65A Steady State		
	Safety	Certifications	UL, NSF	
		Redundant Refrigeration Systems	Yes	
Lock		Yes (Mechanical Keyed)		
Controlled Access		n/a		
Resettable Min/Max Temperature Readings		n/a		
Dry Contacts for Remote System Monitoring		n/a		
System Alerts		n/a		
Storage	Refrigerant	R744 (CO ₂), R718 (H ₂ O)		
	Internal Volume	5.2 cu Ft		
	Shelves	4		
	Catch Tray	1		
	Packing Factor	125 twelve oz. cans or 80 twenty oz. bottles		
Installation	Internal Dimensions	14.7"W x 15.4"D x 38.7"H	37.3 cm W x 39.1 cm D x 98.3 cm H	
	External Dimensions	18.9"W x 20.7"D x 41.8"H	48 cm W x 52.6 cm D x 106.2 cm H	
	Weight	190 lbs		
	ADA Compliant	No		
Warranty	Minimum Clearance Requirement	100mm (rear, top)		
	Heat Pump	10 years		
	Full Refrigerator Parts and Labor	2 years		
	Extended Warranty	Available up to 5 years		

Version 1002A